

MODEL C DRAIN CLEANING MACHINE

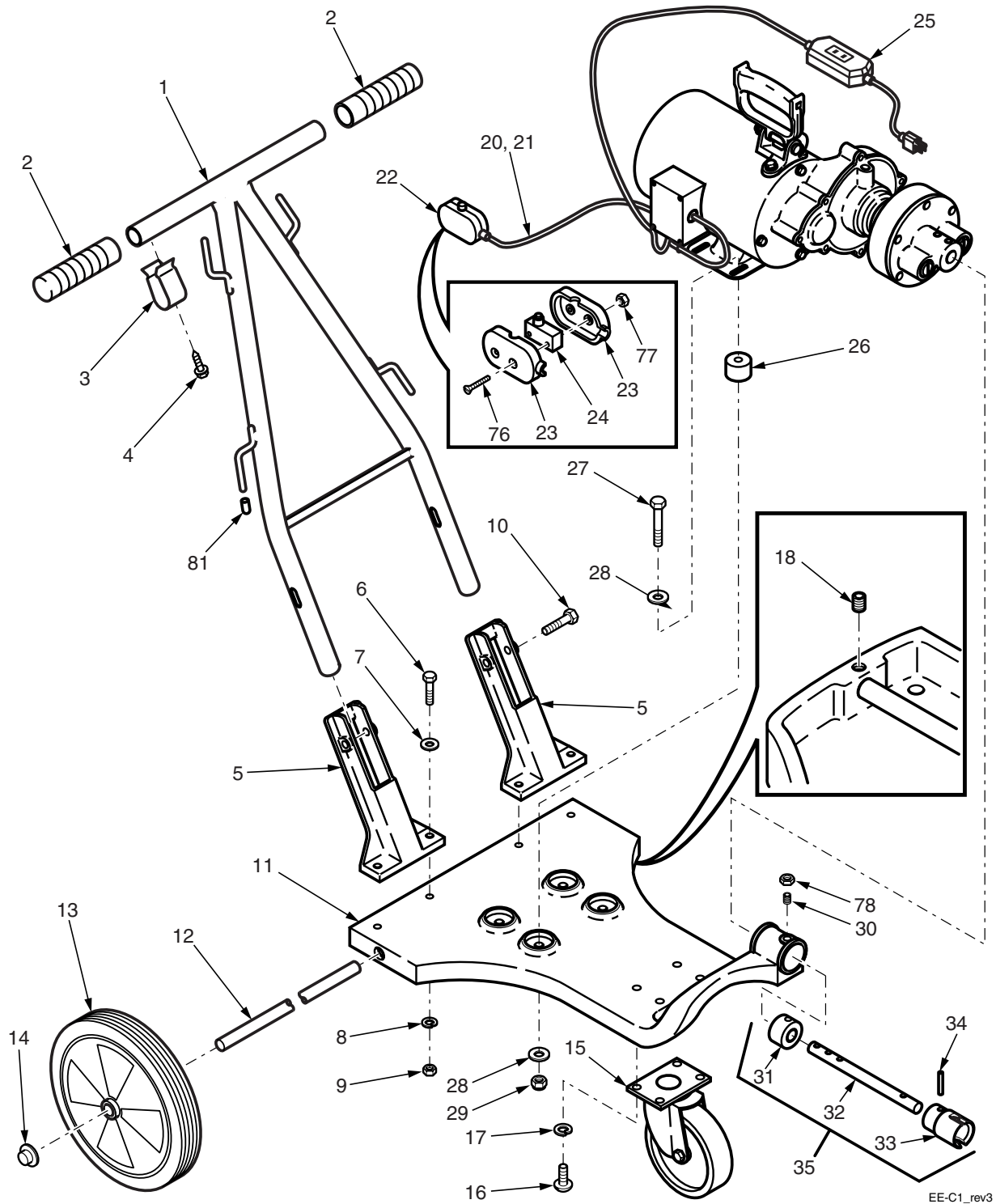

MODEL C DRAIN CLEANING MACHINE

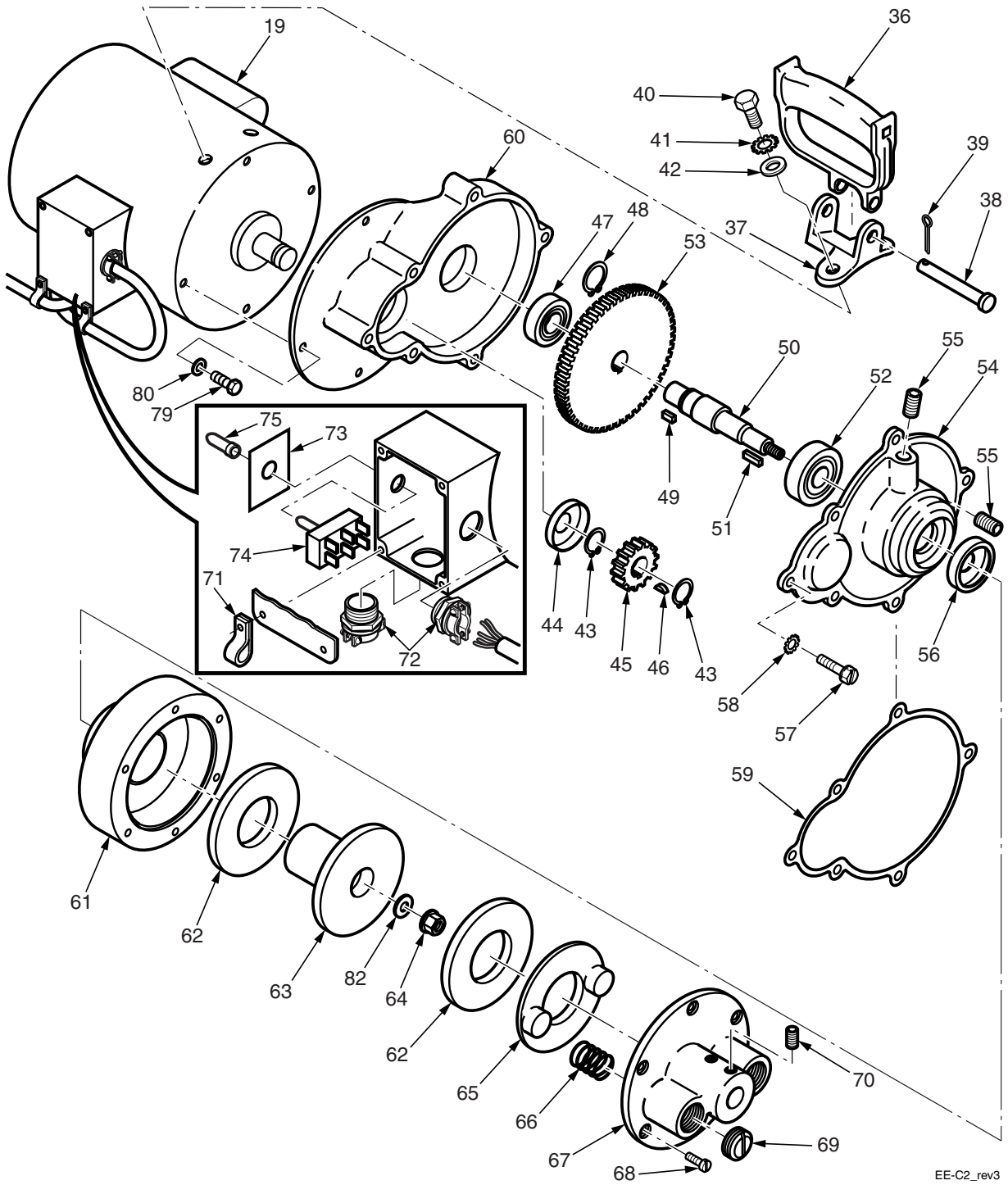

VISIT US ONLINE seca.com.au

MODEL C DRAIN CLEANING MACHINE

ITEM NUMBER	PART NUMBER	DESCRIPTION	AMT
1	DL-9*	Folding Handle	1
2	HG	Handle Grips	2
3	DL-7	Switch Clip	1
4	SM121H	Switch Clip Screw	1
5	DL-10	Bracket (Base of Folding Handle).	2
6	CSHH51618112	Bracket Capscrews	4
7	WA516S	Bracket Washers	4
8	LW516	Bracket Lockwashers	4
9	NU51618FHP	Bracket Nuts	4
10	CSHH3816214	Folding Handle Capscrews	2
11	M-12	Drive Unit Base	1
12	M-13	Axle	1
13	C-W10	10" Diameter x 5/8 Wheels	2
14	PN12	Pushnuts	2
15	C-SWC	Swivel Caster	1
16	MS142058RH	Caster Screw	4
17	LW 14	Caster Lockwasher	4
18	SS5161812	Axle Setscrew	1
19	CM-1/2**	1/2 H.P. Replacement Motor	1
	CM-3/4	3/4 H.P. Replacement Motor	1
	CM-1	1 H.P. Replacement Motor	1
20	C-HSCD-A	15 Ft. 14/2 W/M-10AY Hand Switch	1
21	C-HSCD	15 Ft. 14/2 Cord Only (Less Hand Switch).	1
22	M-10AY*****	Hand Switch with Case Assy	1
23	M-10	Switch Case Only	1
24	YA-2	Momentary Contact Switch (Less Case).	1
25	GFCI	Ground Fault Circuit Interrupter 20' Cord	1
26	M-7	Rubber Mounts	4
27	CSHH516182	Rubber Mount Capscrews	4
28	WA516P	Rubber Mount Flatwashers	8
29	NU51618NY	Rubber Mount Nuts	4
30	SS381634DP	3/8-16 x 3/4 Set Screw Dog Point	1
31	SC-11	Guide Ball	1
32	SC-12	Shaft	1
33	SC-10	Front Coupling	1
34	RP316118	Spiral Pin	1
35	SC-10A***	Fitting	1
	M-4A*****	Handle Assembly	
36	M-4	Carry Handle	1
37	M-5	Bracket	1
38	M-3****	Handle Pin	1
39	CP33234	Cotter Pin	1
40	CSHH5161858	Handle Capscrew	2

MODEL C DRAIN CLEANING MACHINE

ITEM NUMBER	PART NUMBER	DESCRIPTION	AMT
41	LW516E	Handle Lockwasher	2
42	WA516S	Handle Flat Washer	2
43	RR66	Retaining Ring	2
44	471553	Rear Oil Seal for Motor Shaft	1
45	KC-4	Small Gear w/Key	1
46	WK3	Woodruff Key	1
47	6203ZZ	Rear Ball Bearing	1
48	RR75	Retaining Ring	1
49	K31612	Key	1
50	KC-8	Back Gear Shaft	1
51	K31634	Key	1
52	6304ZZ	Front Ball Bearing	1
53	KC-7	Large Gear w/Key	1
54	KC-3	Gear Case Cover	1
55	PP18	Pipe Plug	2
56	7829CR	Front Oil Seal for Back Gear Shaft	1
57	MS102434HHWS	Gear Case Cover Screws	6
58	LW10E	Gear Case Cover Lockwashers	6
59	KC-5	Gear Case Gasket	1
60	KC-2	Gear Case	1
61	GE-30	Clutch Body	1
62	E-2	Clutch Friction Disc	2
63	E-3	Clutch Drive Member	1
64	NU3824NY	Back Gear Shaft Nut	1
65	GE-33	Clutch Pressure Plate	1
66	E-4	Clutch Spring	2
67	GE-31	Clutch Cover Plate	1
68	MS142058FLH	Screw	6
69	E-7	Clutch Adjusting Screw	2
70	SS5161834	Socket Head Setscrew Anchors Item 35	2
71	CH31S10	Wire Clamp	2
72	C-TSC12	Screw Connector	2
73	SW-FRP	Forward/Reverse Switch Plate	1
74	SW-FR	Reversing Switch	1
75	SW-BOOT	Toggle Switch Boot	1
76	MS8321FH	Switch Case Screws	2
77	NU832FHP	Switch Case Nuts	2
78	NU3816J	3/8-16 Jam Nut	1
79	CSHH38161	3/8-16 x 1 Hex Head Capscrew	3
80	LW38I	3/8 Lockwasher - Internal	3
81	DL6CAP	Cord Hook Cap	4

MODEL C DRAIN CLEANING MACHINE

ITEM NUMBER	PART NUMBER	DESCRIPTION	AMT
82	WA38S	3/8 Flatwasher.....	1

* DL-9A - Folding Handle Complete with Hardware. Includes items 1-10 and 81.

** Includes Items 71-75

*** Includes Items 31 - 34

**** Includes Item 39

***** Includes Items 23, 24, 76, 77

***** Includes Items 36,37, 38